



REFRIGERATED COCKTAIL BAR STATION INCL. SINK, GLASS RINSER, SPEEDRAIL FOR BOTTLES, CUTTING BOARD AND WASTE BIN

€5,253.00

SKU:

7083.0050

Refrigerated Stainless Steel Cocktail Bar Station with 3 Drawers – everything within reach for perfect service

This professional cocktail bar station is the complete solution for any hospitality business that values speed, efficiency, and hygiene. Refrigerated, fully equipped, and made from high-quality AISI 304 stainless steel – ideal for busy bars, beach clubs, or event venues. Dimensions 1790x700x875 mm – 0.19 kW power – temperature range -1/+8°C – weight 165 kg.



Key features:

- **Refrigerated drawer layout:** 3x GN 2/3 – perfect for chilled ingredients
- **Complete bar equipment:** including sink, glass rinser, GN compartments, speed rail for bottles, and insulated ice compartments
- **Additional functionality:** built-in (removable) cutting board and waste chute with mobile waste bin
- **Flexible installation:** cut-out for faucet must be made by user (faucet not included)

A compact all-in-one cocktail solution. Order now and make your bar workflow more efficient!

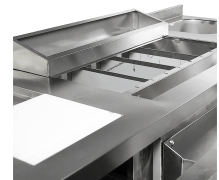



EAN code	6153300661663	Width (mm)	1790
Depth (mm)	700	Height (mm)	875
Material	Stainless steel Aisi 304	Color	Stainless steel
Gross Weight (kg)	185	Net weight(kg)	165
Voltage (Volt)	230	Frequency (Hz)	50
Electrical power (kW)	0,19	Temperature range (°C)	-1/+8
Contents of GN	7x 1/9	Mobile	No
Number of drawers	3	Brand	COMBISTEEL
Energy Class (A/G)	No energy label required	Sink dimensions wxdxh (mm)	330x300x180
Accessories excluded	GN containers		

CombiSteel

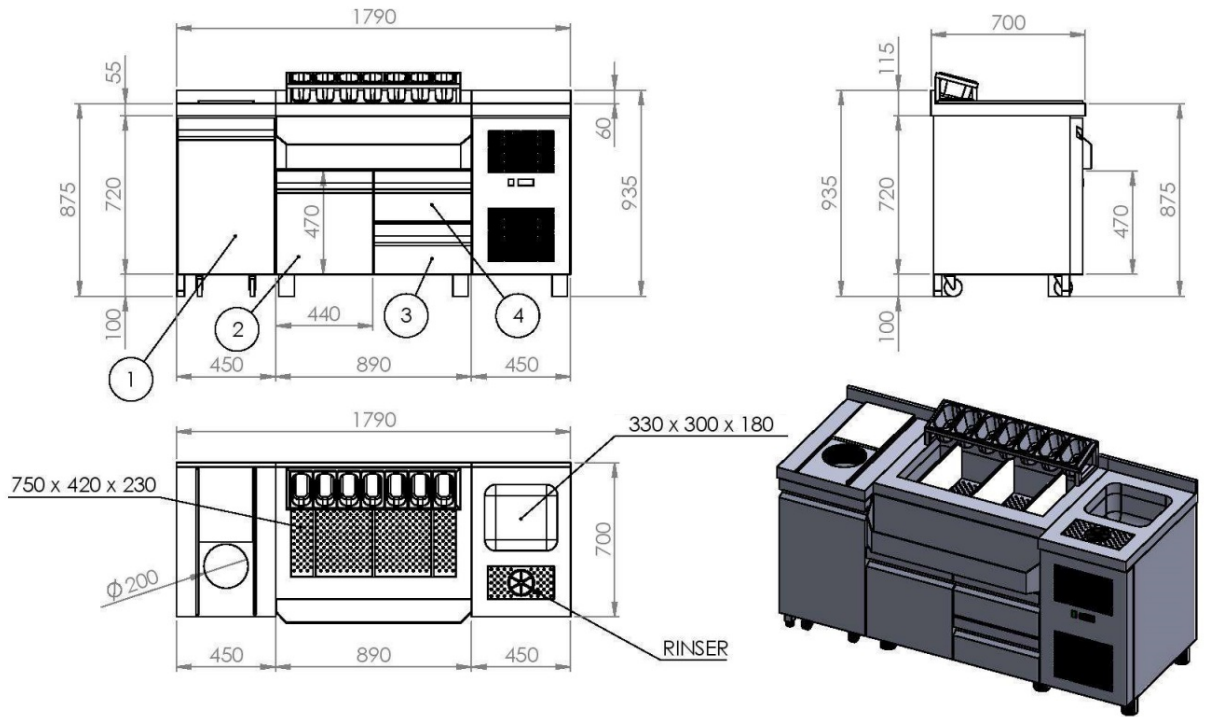

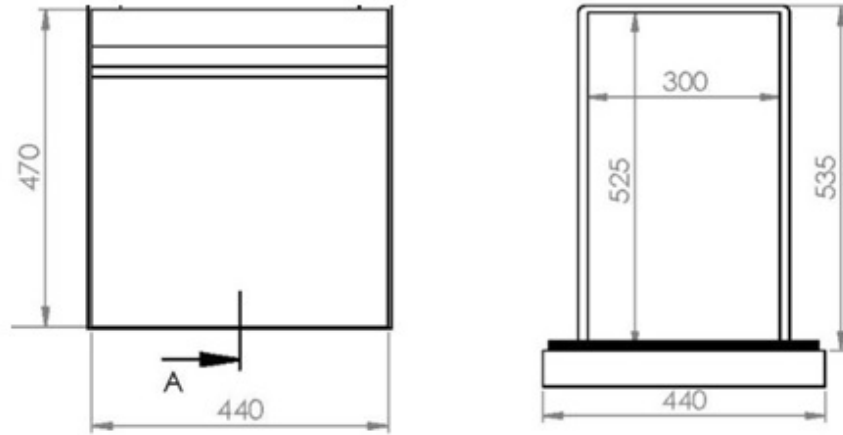

COOLING DRAWER
GN 2/3

NET USABLE SPACE:
300 (L) x 525 (W) x 375 (H)